

**Continental** 

**HDL Eco Plus**



CONTINENTAL  
MEDIUM TRUCK

# HDL Eco Plus

## PREMIUM LONG HAUL DRIVE (HEAVY DRIVE LONG HAUL)

New advanced tread compound provides long original mileage and low rolling resistance.

Closed shoulder tread design provides even tread wear while still providing excellent traction.

Stone ejection system reduces stone retention and casing penetrations.

28/32" tread depth for optimized mileage and rolling resistance.

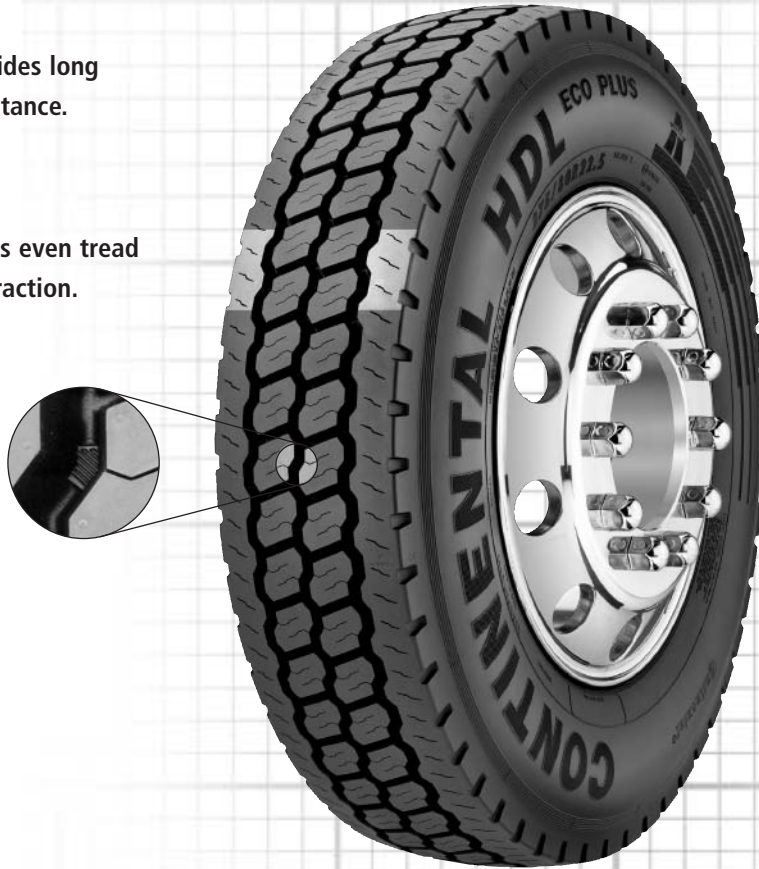

### Applications:

Long haul, over the highway, drive position.

## TIRE SPECIFICATIONS

Highway - 75 mph at loads indicated unless otherwise stated.

TIRE SIZE	LOAD RANGE	TREAD DEPTH	PRODUCT CODE	SAP ARTICLE NUMBER	RIM WIDTH IN	OVERALL INFLATED DIAMETER IN (mm)	OVERALL INFLATED WIDTH IN (mm)	LOADED SECTION WIDTH IN (mm)	STATIC LOADED RADIUS IN (mm)	MINIMUM DUAL SPACING IN (mm)	REVS PER MILE (KM)	TIRE WEIGHT LB (KG)	MAX LOAD@INFLATION			
													SINGLE		DUAL	
												lbs (KG)	psi (KPa)	lbs (KG)	psi (KPa)	
11R22.5*	H	28/32	0109401	05683750000	8.25	42.0 (1066)	11.1 (282)	12.1 (307)	19.6 (498)	12.5 (318)	493 (306)	127 (58)	6610 (3000)	120 (830)	6005 (2725)	120 (830)
11R24.5	H	28/32	0109402	05683760000	8.25	44.0 (1117)	11.1 (282)	12.1 (307)	20.6 (523)	12.5 (318)	470 (292)	136 (62)	7160 (3250)	120 (830)	6610 (3000)	120 (830)
275/80R22.5*	H	28/32	0109410	05683770000	8.25	40.8 (1036)	11.0 (279)	12.1 (307)	18.9 (480)	12.5 (318)	507 (315)	122 (55)	6940 (3150)	120 (830)	6175 (2800)	120 (830)
285/75R24.5	H	28/32	0109426	05683780000	8.25	42.0 (1066)	10.7 (272)	12.1 (307)	19.6 (498)	12.5 (318)	493 (306)	128 (58)	6780 (3075)	120 (830)	6175 (2800)	120 (830)

Note: Minimum Dual Spacing calculated without chains.  
These specifications subject to change without notice.

\*ECE Certified

Form #: SS-HDLE+ 01/03 ©Continental Tire North America, Inc. 2003